

FC-7S High precision fiber cleaver instruction manual

Method of use and regulation of safety operation.

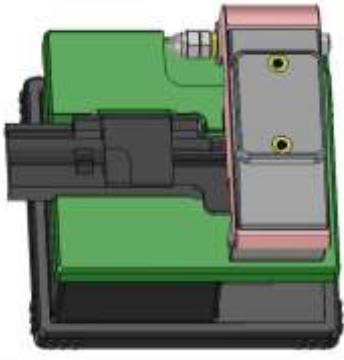

- Please read the instruction manual carefully before operation, keep instruction manual and fiber cleaver in a good place at the same time.
- In order to prevent the damage of the machine performance, please note the following when you use fiber cleaver.
- Don't get wet fiber cleaver.
- Don't put the fiber cleaver in a place where is wet or dusty.
- Under normal temperature preservation in order to avoid high temperature cause deformation.
- Don't hit so hard fiber cleaver.
- Leave about 12 mm long bare fiber.
- Regularly clean up dirt on pressure fiberboard with alcohol, don't use acetone or corrosive solvent cleaning pressure fiberboard.
- Constantly clean up fiber box and ensure no dust and oil dirties in the slot.

Product model	Fiber cleaver
optical fiber cladding diameter	125μm
Fiber coating diameter	0.25mm-0.9mm
Coated outer diameter	Single core
The length required to be removed before optical fiber cutting	Fiber cutting length ≥18mm
Fiber cutting length	5-20mm
Fiber cutting angle	≤0.8°
Blade life	48000 (1000timesx16 positionx3high)
Size	63Wx65Dx60H(mm)
Weight	280g(coffee color)/180(black color)
Fxture	Three in one multifunction jip

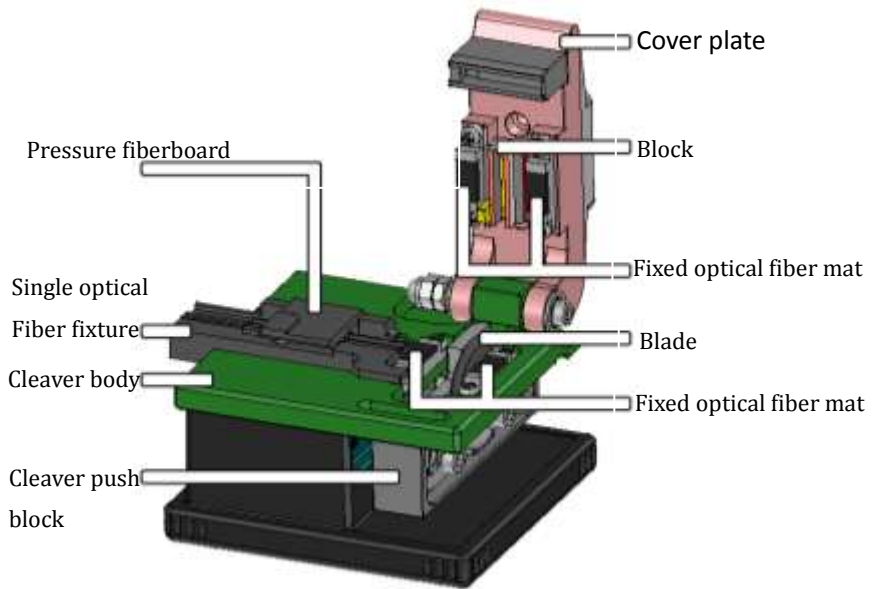

Operating steps

<p>1. Open the pressure fiberboard and cover plate, put bare fiber in the fixture that was stripped coating (125mm/900mm), according to user's requirement to ensure cutting length.</p>		<p>2. Push to the front of the cutting slider (Figure), press and close the pressure fiberboard and cover plate to fix optical fiber.</p>	
<p>3. After close cover plate, ensure that the fiber is in a horizontal line.</p>		<p>4. Push cutting slider back a one-time to finish cutting.</p>	
<p>5. Open cover plate and pressure fiberboard, then take out the fiber. In order to avoid damaging the fiber, fiber face don't touch anything after take it out.</p>		<p>6. After finish cutting, please clean up the broken fiber and don't damage blade for later use.</p>	

Blade's replacement and adjustment

- ⊙ 0-15 cutting points are indicated on the blade.
- ⊙ Please clean up blade and fiber fixture when the cleaver cannot be used properly (Do not wipe fixed optical fiber mat with alcohol).
- ⊙ If it still doesn't work, please adjust the position of the blade.

Please according to the following operation sequence when you adjust the position of the blade.

A. Adjust the blade (According to the mark on the blade 0-15 face to turn)

1. Provide "—" type screwdriver for yourself.

2. First, loose the screw on the blade with "—" type screwdriver (Figure) and adjust the position of blade. Turn one face every time and fix blade. If it still doesn't work, the following steps need to adjust blade and the height of the cutting slider.



B. Adjust blade height

1. The blade below the two hexagonal screws are loosen by hex wrenches. (Figure)



2. Slightly adjust the screw right as shown. Clockwise to lift the blade, and vice in order to lower the blade height.



3. Open pressure fiberboard and cover plate, put bare fiber in the fixture that was stripped coating (125mm/900mm), press and close pressure fiberboard, push cutting block back and forth, then you can see the fiber cleaver's blade whether just meet fiber or not, if not, please repeat step 2.

Lift blade, if meet too much, please repeat step 2 to lower blade. Adjust the best position, then tighten two hexagonal screws that's loosen in the first step with hex wrenches.

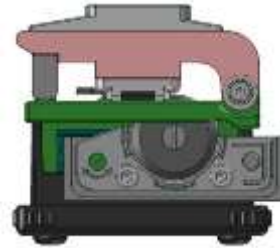

C. Replace new blade

1. Remove the old blade, install the new blade..

2. According to "Adjust blade height" to adjust blade's high or low.

Attention: please don't adjust cleaver with inappropriate "—" type screwdriver or hex wrenches.

D. Optional accessory

standard



optional



optional



Attention: please don't adjust cleaver with inappropriate "—" type screwdriver or hex wrenches.

Anything, please feel free to contact with us:

www.baudcom.com.cn

info@baudcom.com.cn

tel: +862137709251